

1201

1203

Income Producing Site Development Opportunity

1201-1203 KENT ROAD | RALEIGH, NC 27606

Table Of Contents

3	Property Overview
4	Photos
5	Floor Plan
7	Parcel Map
8	Aerial View
9	Conceptual Site Plan
10	Location Map
11	NC State Overview
12	Raleigh Market Overview

Property Overview

\$3,500,000

Asking Price

6,216 SF

Total SF

2,145 SF

1203 Kent Rd.

4,071 SF

1201 Kent Rd.

Single

Tenancy

1.62 ac

Lot Size

R-10

Zoning

KEY AMENITIES

- Covered land deal with potential for town-homes or apartments
- Currently deeded into parcels that has 2 buildings that can be rented separately.
- Conveniently located 0.3 miles from I-440
- Located 1.0 mile from NC State Campus
- 34 parking spaces

Lease Abstract:

Lease Expiration:	September 30, 2025
Current Rent:	\$8,487.20
NOI:	\$101,846.40
Escalator:	3% - December 2024



1201 Floor Plan

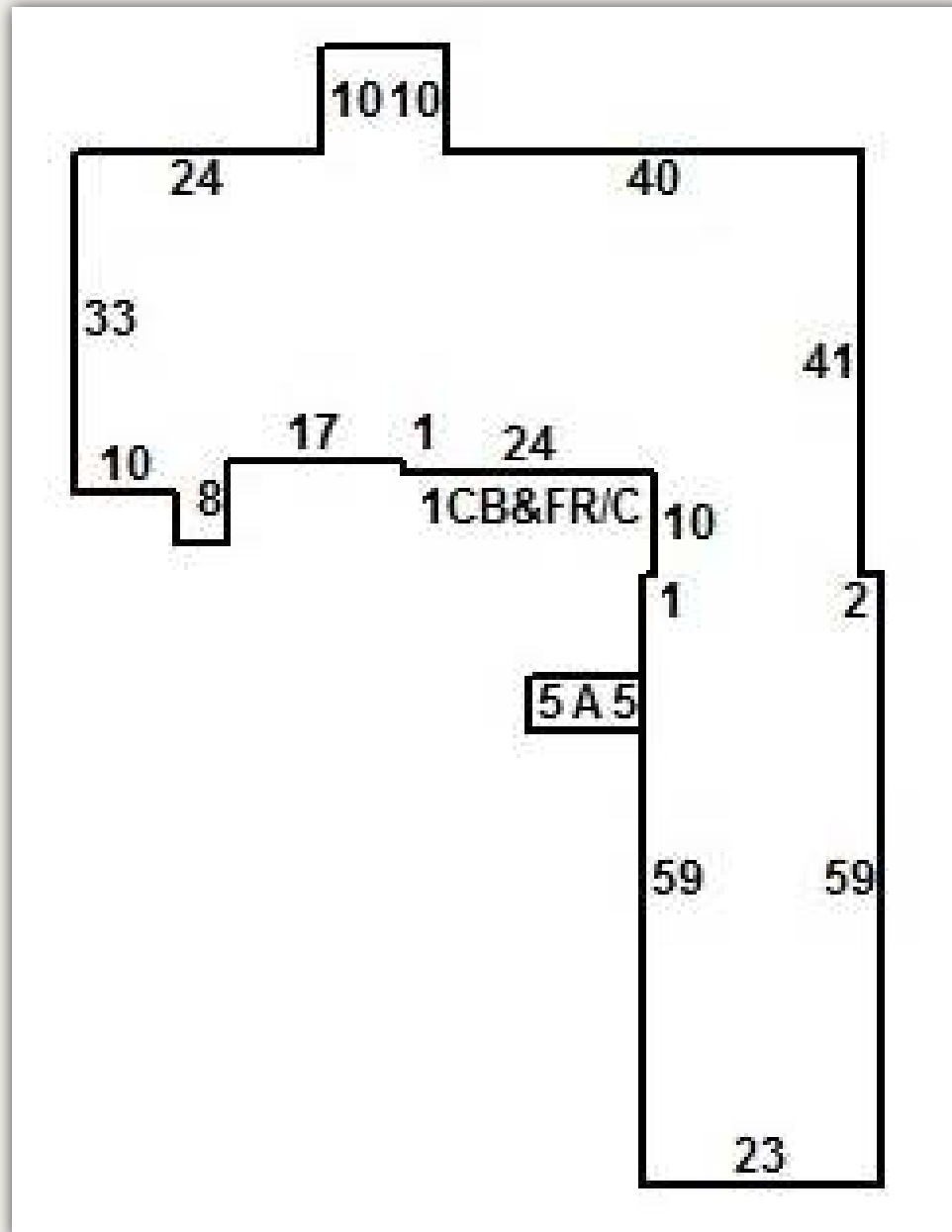

1203 Floor Plan

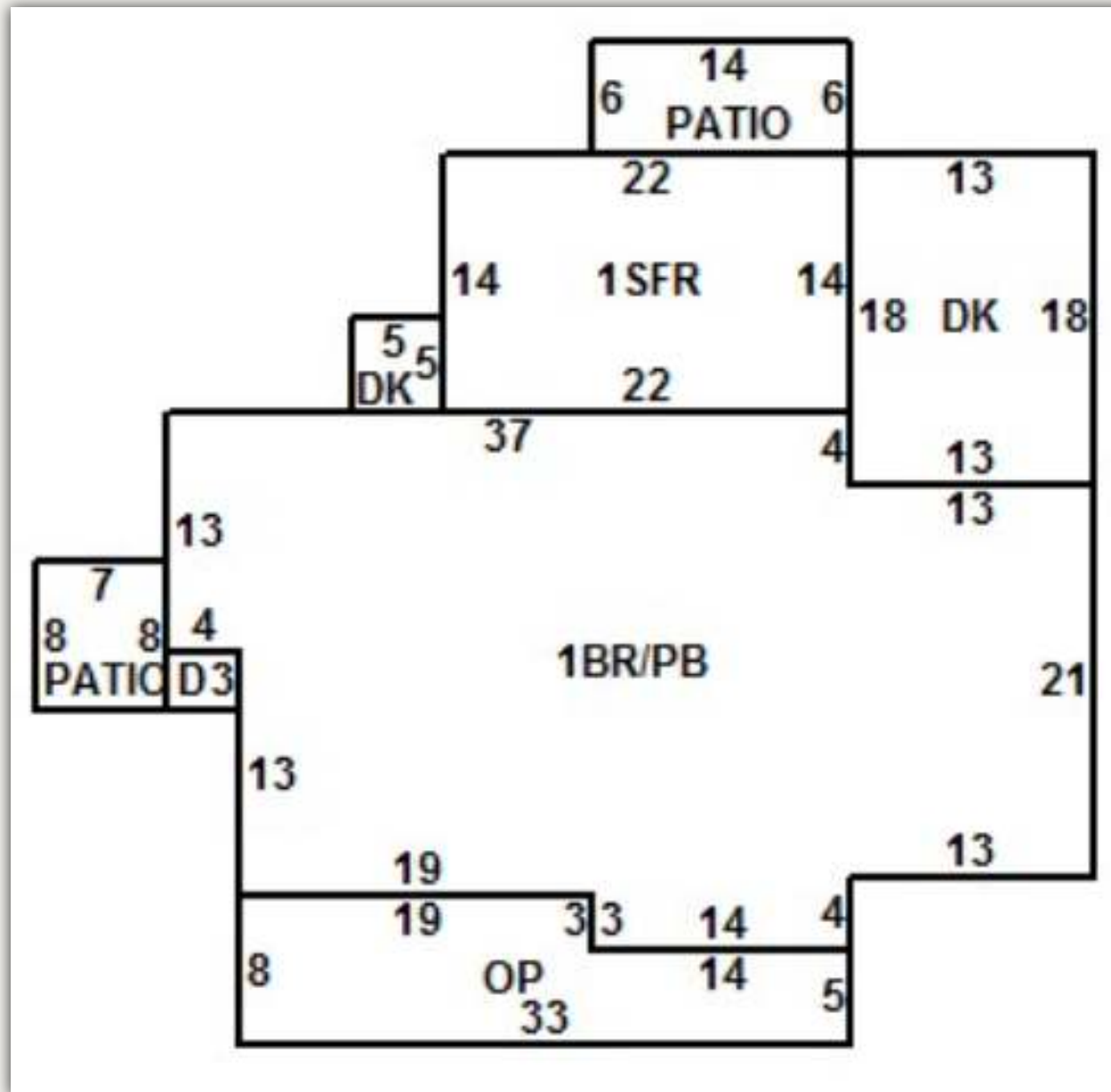

Parcel Map



R10 Zoning

10' BLDG SETBACK

PIN: 0793190817 - .81 AC

AMENITY
3030 sf

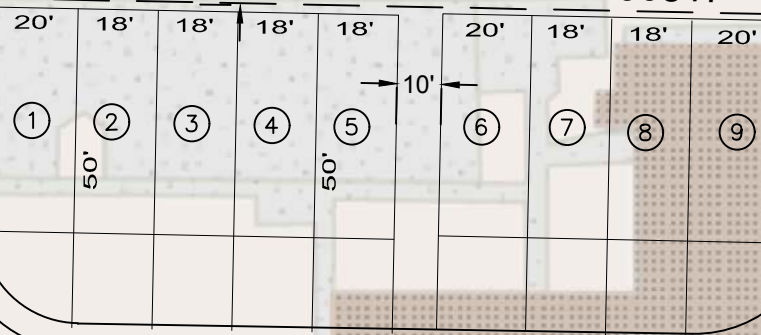

AMENITY
1709 sf

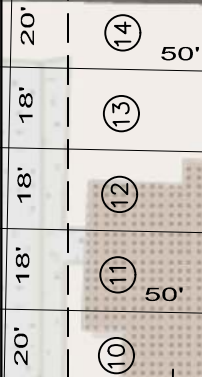

R10 Zoning

AMENITY
2300sf

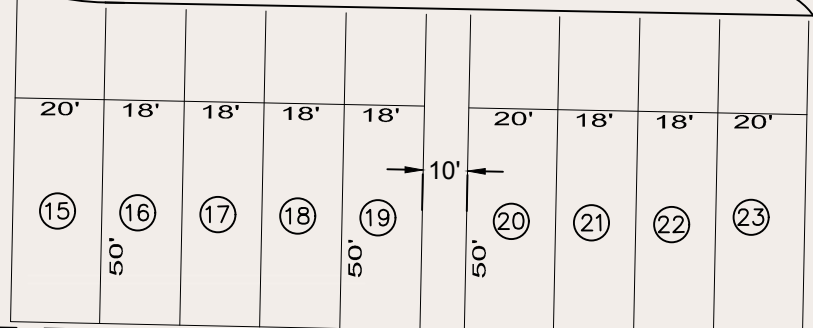

PIN: 0793190717 - .81 AC

10' BLDG SETBACK

$$1 / 3000 \text{ sf} = 70,567 / 300 = 23$$

R10 Zoning

NC GRID NAD 83 (2011)
20' BLDG SETBACK

Conceptual site plan shows 23 units

Gettle Engineering and Design, PLLC

3616 Waxwing Court,
Wake Forest, North Carolina 27587
(919) 210-3934 Firm License P-2538

PRELIMINARY
DO NOT USE FOR
CONSTRUCTION



Western Blvd (53,000 VPD)

Kent Rd

1201

1203



NC STATE UNIVERSITY
(WEST CAMPUS)

Western Blvd (53,000 VPD)

Kent Rd

1203

1201

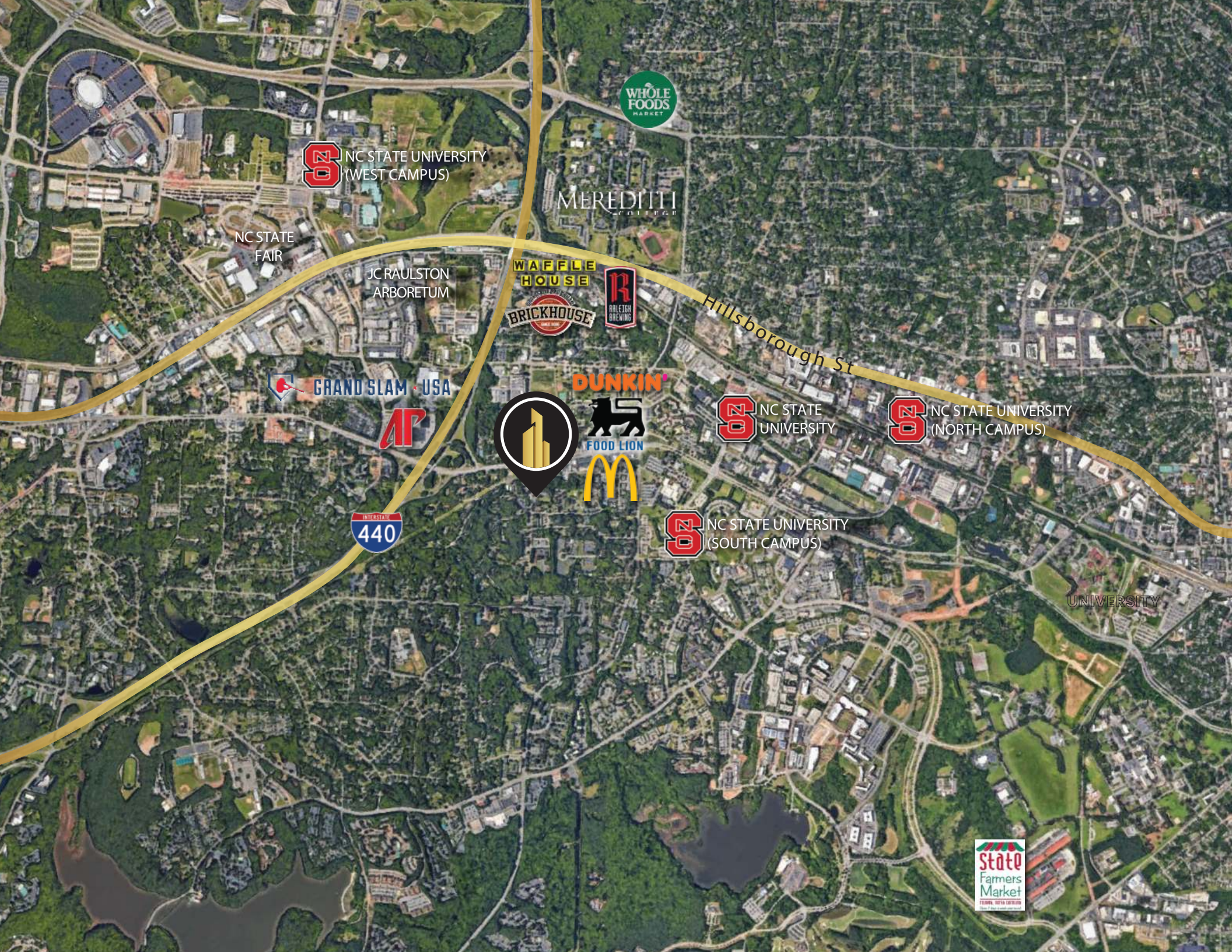

NC STATE UNIVERSITY (WEST CAMPUS)

MEREDITH COLLEGE

NC STATE FAIR

JC RAULSTON ARBORETUM

WAFFLE HOUSE



Hillsborough St

GRAND SLAM USA

DUNKIN'

NC STATE UNIVERSITY

NC STATE UNIVERSITY (NORTH CAMPUS)



NC STATE UNIVERSITY (SOUTH CAMPUS)



UNIVERSITY





NC STATE UNIVERSITY

24,437
Undergraduates

9,516
Graduate and professional students

North Carolina State University, commonly known as NCSU or NC State, is a public, coeducational, research university in Raleigh, NC. As the largest university in the state, it is known for its leadership in education and research, and globally recognized for its science, technology, engineering and mathematics leadership. NC State is home to 12 undergraduate colleges, a graduate school, two professional schools, and over 2,000 faculty members.



60
Doctoral Programs

120
Master's Programs

100
Undergraduate Programs

#1

Largest public university in North Carolina

100+

Startups and spin offs based on NC State research, attracting a total of \$1.6 billion in venture capital

\$300 + Million

In new sponsored research awards and the only university in the nation leading two National Science Foundation Engineering Research Centers

- > Average starting salary for graduates out of all NC public colleges | onlinecollegesdatabase.org
- > Best Value College among North Carolina universities SmartAsset.com
- > College of Veterinary Medicine in the nation | U.S. News & World Report
- > Best value among U.S. public universities | Princeton Review
- > Best value among U.S. public universities | U.S. News & World Report
- > On-campus includes all college owned, operated or affiliated properties.

MARKET OVERVIEW - RALEIGH, NC



Raleigh is the capital of the state of North Carolina and the seat of Wake County in the United States. Raleigh is the second-largest city in the state, after Charlotte. Raleigh is known as the "City of Oaks" for its many oak trees, which line the streets in the heart of the city. The city covers a land area of 142.8 square miles. The U.S. Census Bureau estimated the city's population as 479,332 as of July 1, 2018. It is one of the fastest-growing cities in the country.

Raleigh is home to North Carolina State University (NC State) and is part of Research Triangle Park (RTP), together with Durham (home of Duke University and North Carolina Central University) and Chapel Hill (home of the University of North Carolina at Chapel Hill). The "Triangle" nickname originated after the 1959 creation of the Research Triangle Park, located in Durham and Wake counties, among the three cities and their universities. The Research Triangle region encompasses the U.S. Census Bureau's Raleigh-Durham-Chapel Hill Combined Statistical Area.

Most of Raleigh is located within Wake County, with a very small portion extending into Durham County. The towns of Cary, Morrisville, Garner, Clayton, Wake Forest, Apex, Holly Springs, Fuquay-Varina, Knightdale, Wendell, Zebulon, and Rolesville are some of Raleigh's primary nearby suburbs and satellite towns.

#1

Best City To Start A Tech Career
(Raleigh-durham-chapel Hill, Nc)
Go Banking Rates

Most Liveable City in the U.S
Far & Wide

#2

Fastest Growing Metro In The U.S
-*Inspection Report Network*

Among The South's Best Cities
On The Rise 2022
-Southern Living

CONFIDENTIALITY DISCLAIMER

The information contained in this Offering Memorandum is proprietary and strictly confidential. It is intended to be reviewed only by the party(ies) receiving it from CityPlat, LLC and should not be made available to any other person or entity without the written consent of CityPlat, LLC. If you are not the intended recipient, you are hereby notified that any retention, dissemination, duplication, forwarding, copying or taking any action in reliance on the contents of this information is strictly prohibited. If you receive this Offering Memorandum in error, whether in electronic or printed form, please notify the sender and destroy the document.

This Offering has been prepared to provide a summary of unverified information to prospective purchasers, and to establish only a preliminary level of interest in the subject property. The information contained herein is not a substitute for a thorough due diligence investigation.

CityPlat, LLC has not made any investigation, and makes no warranty or representation, with respect to the income or expenses for the subject property, the future projected financial performance of the property, the size and square footage of the property and improvements, the presence or absence of contaminating substances, PCB's or asbestos, the compliance with state and federal regulations, the physical condition of the improvements thereon, or the financial condition or business prospects of any tenant, or any tenant's plans or intentions to continue its occupancy of the subject property.

The information contained in this Offering has been obtained from sources we believe are reliable; however, CityPlat, LLC has not verified, and will not verify, any of the information contained herein, nor has CityPlat, LLC conducted any investigation regarding these matters and makes no warranty or representation whatsoever regarding the accuracy or completeness of the information provided.





NIKITA ZHITOV
Principal
919.888.1285
nikita@cityplat.com

LAUREN WILLIAMS
Broker
919.538.1594
lauren@cityplat.com

107 FAYETTEVILLE ST.
SUITE 400
RALEIGH, NC 27601

WWW.CITYPLAT.COM